

(No Model.)

J. SEIBERT.

STEADY REST FOR LATHES.

No. 346,324.

Patented July 27, 1886.

Fig. 1,

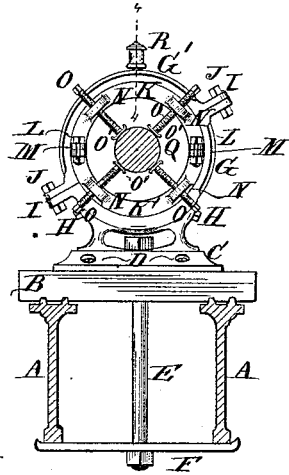

Fig. 4,

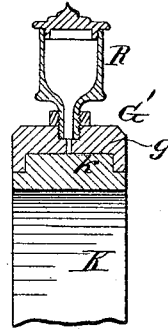

Fig. 2,

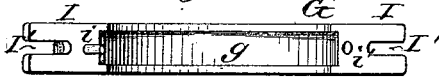
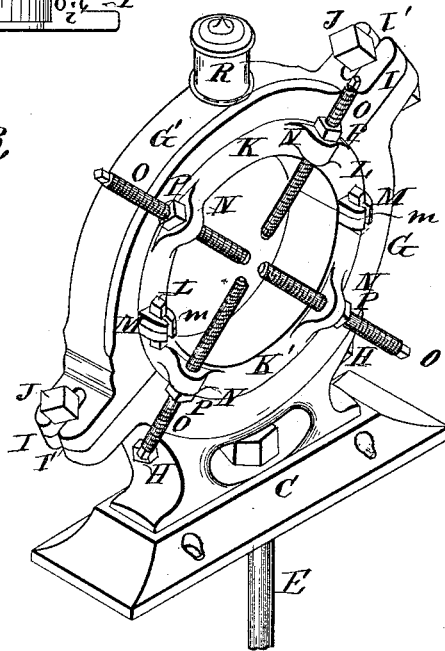

Fig. 3,



Attest;
F. A. Mopping
Geo. S. Wheelock

Inventor
Joseph Seibert
By Knight Bro.
attys.

UNITED STATES PATENT OFFICE.

JOSEPH SEIBERT, OF ST. LOUIS, MISSOURI.

STEADY-REST FOR LATHES.

SPECIFICATION forming part of Letters Patent No. 346,324, dated July 27, 1886.

Application filed April 24, 1886. Serial No. 200,032. (No model.)

To all whom it may concern:

Be it known that I, JOSEPH SEIBERT, of the city of St. Louis, in the State of Missouri, have invented a certain new and useful Improvement in Steady-Rests for Lathes, of which the following is a full, clear, and exact description, reference being had to the accompanying drawings, forming a part of this specification, and in which—

Figure 1 is an elevation of the device, showing the shears of the lathe and the stuff being turned in transverse section. Fig. 2 is a perspective view of inside of the upper member of the yoke. Fig. 3 is a perspective view of the device, and Fig. 4 is an enlarged vertical section at 4 4, Fig. 1.

This is a device for steadying in a wood or metal lathe objects whose length is great as compared with their diameter, and which are thus liable to spring in turning. It has a yoke fixed to the lathe-shears between the heads, and in the yoke turns a chuck-ring, in which the stuff is held by centering-screws.

The lathe-shears are shown at A.

B is a block of wood or metal fitted to the shears, and which should be capable of end-wise adjustment of the shears.

C is the base of the yoke, and which may properly be made of cast-iron. This base is shown attached to the block B by screws D; but the attachment may be made by any other means.

E is a clamping-screw extending through the base and block, and through a cross-bar, F, beneath the lathe-shears, and which holds both the base and the block firmly to the shears.

The yoke-ring consists of two semi-annular sections, G G', the lower one of which is secured to the base C by bolts H or other means. I prefer to make the yoke of gun-metal, so as to give smooth bearing to the chuck. The semi-annular sections G G' are secured together by lugs I, having open-ended slots I', through which pass screw-bolts J.

i are steady-pins, and i' pin-holes in which the steady-pins rest.

It will be seen that the sections G G' are set

at an inclination, the front ends being the lower, to facilitate the introduction and removal of the stuff when the upper section has been removed.

The interior of the yoke has an annular channel, g, which receives a circumferential rib, k, of the chuck-ring. The chuck-ring is composed of two semi-annular sections, K K', and may very properly be made of steel or iron. The sections are secured together by bolts L, occupying open-ended slots m in the side lugs, M, of these sections. The faces of the lugs may have steady-pins and pin-holes like the lugs I.

N are lugs upon the sides of the chuck, in which work centering-screws O, upon which may be jam-nuts P. (See Fig. 3.)

The points of the screws O may be made to bear directly against the stuff Q, or the points of the screws may have bearing shoes or plates O', forming the means of bearing against the stuff.

R is an oiler lubricating the bearing g k.

In Fig. 1 the stuff is shown round; but it may be of any form, (in section,) as the centering-screws can be accommodated to any shape.

I claim—

1. The combination, with the yoke and the chuck-ring bearing therein, of the centering-screws tapped through said chuck-ring, and having the jam-nuts, substantially as set forth.

2. The combination, with the sectional yoke, of the sectional chuck-ring bearing therein, the lugs projecting from the respective ends of said chuck-ring sections in the direction of the axis of rotation, and bolts securing said lugs together, substantially as set forth.

3. The combination of the sectional yoke, the sectional chuck-ring bearing therein, and having the tapped lugs projecting from the end thereof, and the centering-screws passing through said lugs, substantially as set forth.

JOSEPH SEIBERT.

In presence of—

BENJN. A. KNIGHT,
SAML. KNIGHT.